



FL440



FL330 | FL440 BAC EUROPE



FL660 PALLOX



Lame

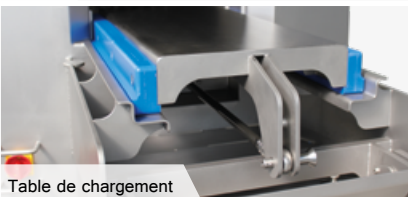
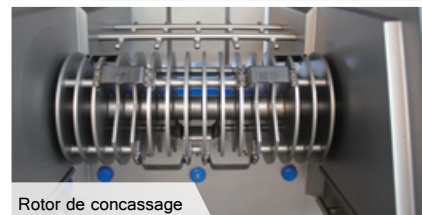

Table de chargement

- Travail de blocs congelés
- Tous types de matières (viande, poisson, fromage..)
- Capacité de production allant de 1500 à 8000kg/h
- Sortie Bac Europe (FL330 et 440) ou pallox (FL660)
- Sortie sur convoyeur
- Conception hygiénique



Lame



Rotor de concassage

Les grignoteuses permettent de dégrossir les blocs congelés en copeaux

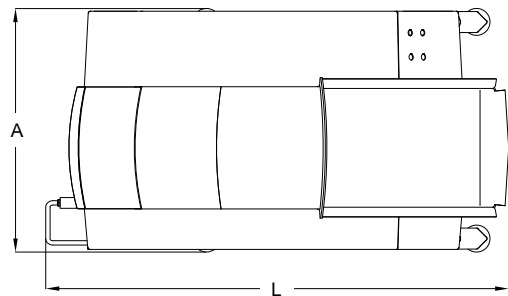
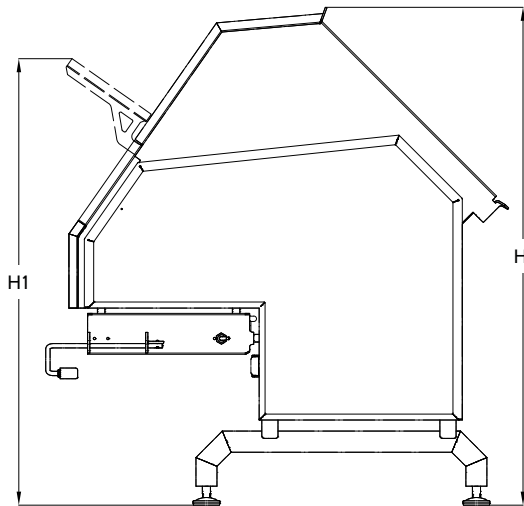
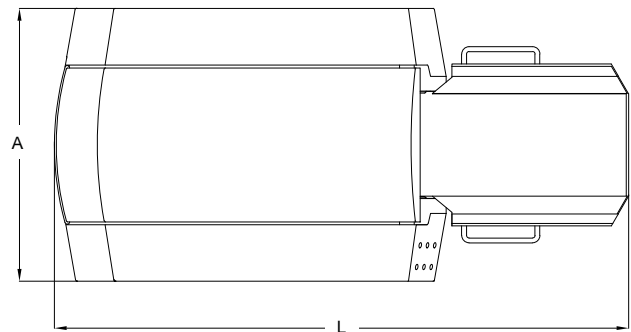
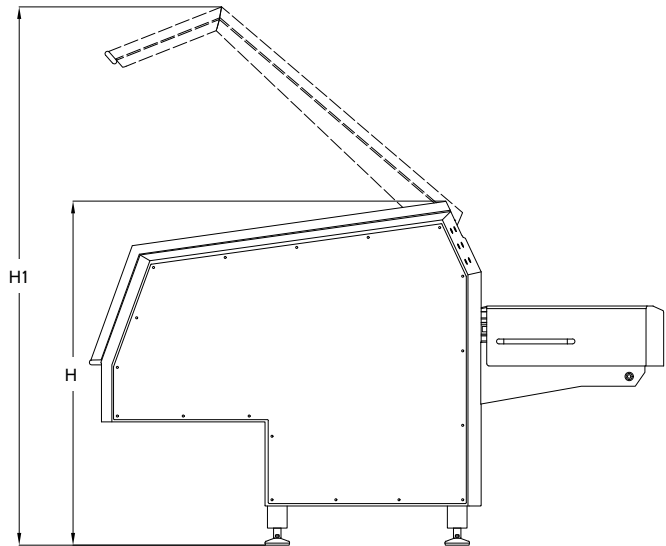

N&N GRIGNOTEUSES		FL330	FL440	FL660
RENDEMENT THÉORIQUE	[KG/H]	1500	4000	8000
ÉPAISSEURS DE COUPE	[MM]	3   6   9	3   6   9	3   6   9
ÉPAISSEURS DE COUPE	[MM]	14   17   20	14   17   20	14   17   20
NOMBRES DE LAMES		4	4	7
VITESSE DE ROTATION DU ROTOR	[TR/MIN]	130	vitesse 1 : 70 vitesse 2 : 140	112
PUISSANCE MOTEUR	[KW]	7,5	9,2 / 11,5	18,5
RACCORDEMENT ÉLECTRIQUE	[V]	400	400	400
AMPÉRAGE	[A]	20	32	50
POIDS NET	[KG]	590	980	1860
PUPITRE OPÉRATEUR		Boutons poussoirs	Boutons poussoirs	Boutons poussoirs
DÉCHARGEMENT		Bac Europe 200L	Bac Europe 200L	Pallox
OUVERTURE DU CAPOT	[KG/H]	Manuelle	Pneumatique	Pneumatique
PRESSION NÉCESSAIRE	[KG/H]	-	6	6
TEMPÉRATURE DU BLOC ADMISSIBLE	[°C]	-20	-20	-20

**FL330**

**FL440 | FL660**

N&N GRIGNOTEUSES		FL330	FL440	FL660
HAUTEUR MACHINE FERMÉE H	[MM]	1850	1410	1780
HAUTEUR MACHINE OUVERTE H1	[MM]	1660	2110	2690
LONGUEUR L	[MM]	1720	2360	2950
LARGEUR A	[MM]	900	1120	1600